

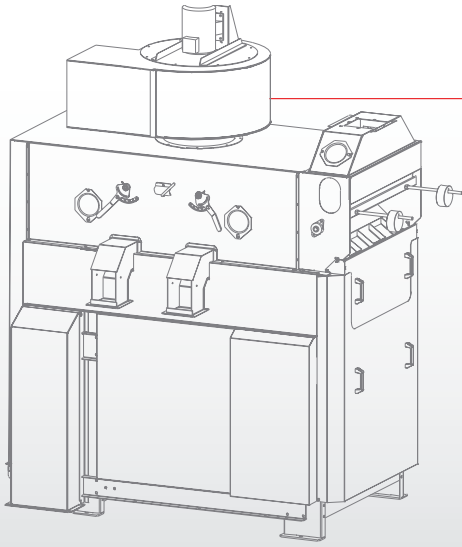

# Cleaner Separator NSD



# General description

The NSD **DENIS** cleaner separator, the latest addition to the DENIS family of cleaners, benefits from 150 years of DENIS know-how and experience in the field. Robust, compact and reliable as all other DENIS separators, it comes with some interesting features, increasing its performances and flexibility. It has been designed for standard cleaning at 50 TPH (on wheat), and much more :

**Two screen boxes** to improve balancing & reduce vibrations.

**Rubber balls** for screen cleaning, which need no adjustment or maintenance.

**Initial and final aspiration**

- precise aspiration is provided using high air lifting chimneys,
- carried out on the total grain flow before and after splitting the flow for each screen box,
- aspiration efficiency is maintained keeping efficiency with a double cascade of grain allowing no fouling or unwanted air entry.

**Large screen area** with split screens which allow easy screen change with a simple release system, even after long operating periods.

**Flexibility in operation:**

- Typically for standard cleaning, when both screens are used,
- the upper screens remove large impurities (scalping),
  - the lower screens removes small impurities (screening).

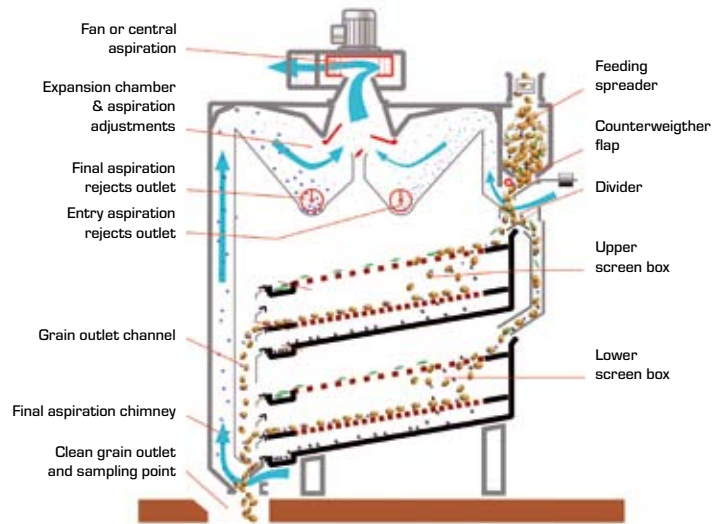

**All screens for oversize material**

For **precleaning**, or when cleaning rapeseed for example, when only scalping is required, one can use **all screens for scalping** and increase throughput by **doubling** the effective screen area.

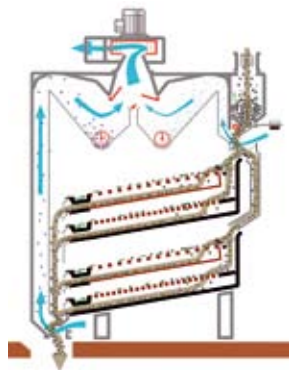

**All screens for undersize material**

When **grading malting barley** for example, when only the lower screens are actually used for removing small grains, with a simple outlet exchange, one can use **all screens for screening** and increase grading efficiency by **doubling** the effective screen area.

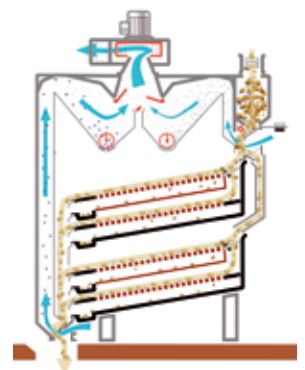

## Characteristics

Cleaner Separator	Length (mm)	Width (mm)	Height (mm)	Power (kW)	Weight (kg)	Airflow (m <sup>3</sup> /h)	Screen area (m <sup>2</sup> )	Output for standard cleaning
NSD	2600	1500	3050	1.5 + 4.0	1270	9000	6.0	50 TPH*

\*On wheat 750 kg/m<sup>3</sup> humidity 16 %



With the screens split, changing screens remains easy even after a long run on dirty grain, due to the simple release system.

**Option**

Dividers and removable bottoms allow all the available screen area to be used for either all scalping or all screening.

**CE** All our machines meet legal safety requirements



Avenue Louis-Denis - 28160 Brou - France  
 Tel. +33 (0)2 37 97 66 11 • Fax +33 (0)2 37 97 66 40  
 www.denis.fr



*The characteristics related to this documentation are given as an indication only and can be modified at any time without notice to improve the product. The manufacturer cannot in any way be held responsible for these changes.*